

Colour laser multifunction product



Lexmark XS950 Family

Digs deep. Does more. Dazzles with colour.



Model shown features additional options



Colour



Touch screen



Copy



Scan



Fax



Solutions



A3 (11x17)



Up to
55 ppm



Duplex



Network

Founded from an IBM heritage in Lexington, Kentucky, in 1991, Lexmark is one of the few American companies to own, develop and market inkjet, laser and colour laser print technologies. Lexmark is poised to deliver on its promise to produce quality, dependable products well into the future.

Make a lasting impression with award-winning colour

The documents you print define an important image—yours. That's why Lexmark colour MFPs help businesses be more productive and stand out with vibrant colour. With the ability to print professional quality colour in-house, you can add instant impact and save costs by virtually eliminating the need to outsource print jobs. Lexmark also offers a host of colour-access and control tools to manage cost.

Eco-responsible

Printing responsibly means everyone wins—your business, your budget and the environment. Lexmark's award-winning products are designed for ease of use, high quality output and reliable performance, with innovative capabilities that help you minimise the number of cartridges you use over the life of the printer and conserve paper and energy. Our goal is to design, package and deliver innovative products and solutions in an environmentally responsible manner.

The Lexmark Cartridge Collection Program is active around the world providing a variety of methods for free returns of your empties to Lexmark or our collection partners. Our goal: Make it easy to do the right thing.

Environmental protection is a shared responsibility

Through our work with industry groups, Lexmark helps guide the formation of standards and guiding principles for environmental sustainability.

Our memberships include:

- ▶ AeA Europe
- ▶ American National Standards Institute (ANSI)
- ▶ Ecma International
- ▶ Electronics Industry Citizenship Coalition (EICC)
- ▶ European Information & Communications Technology Industry Association (EICTA)
- ▶ Information Technology Industry Council (ITI)
- ▶ Environmental Leadership Council





Affordable colour output

The Lexmark XS950 Family delivers high quality A3 colour multifunction performance in an affordable, compact design. Enjoy the benefits of vibrant, professional-quality output on a wide variety of media, allowing you to do more colour printing in-house.

- ▶ PANTONE® calibration for consistent colour tones
- ▶ Named Colour Replacement for easy colour matching
- ▶ Supports SRA 3 media format (320 x 450 mm)
- ▶ Lexmark Colour Care Technology to manage colour usage and control costs

Easy and intuitive

The Lexmark XS950 Family is designed for easy operation and maintenance.

- ▶ Extra large, easy to navigate 25.9 cm colour touch screen provides audible and tactile feedback to make completing tasks intuitive
- ▶ Print and scan preview features help you select documents or specific pages within a document
- ▶ Ability to change settings, such as duplex, at the device
- ▶ Robust connectivity makes it easy to integrate into almost any network environment
- ▶ Sleep Button and Hibernate Mode to reduce energy costs
- ▶ Device management software available

Business productivity

The Lexmark XS950 Family combines high-performance printing, copying, scanning and faxing with time-saving solution applications designed to boost your productivity.

- ▶ Print and copy speeds as fast as 55 ppm
- ▶ Advanced copy functions include the ability to interrupt long print runs to make a quick copy, and proof the first copy set before completing your copy job
- ▶ Scan to multiple destinations, including scan to email, scan to FTP, scan to fax, scan to network, and more
- ▶ Preloaded applications to drive greater efficiency, and Lexmark Embedded Solutions
- ▶ Framework to further extend the capabilities of the device

Save time and money through solutions

Reduce unnecessary printing and simplify work processes through Lexmark solutions. The XS950 Family features the Lexmark Embedded Solutions Framework (eSF), our platform that enables you to add a wide range of software applications directly onto the device. Solutions are designed with your productivity in mind, helping you streamline—or even eliminate—paper intensive business processes.

The right touch

The Lexmark e-Task colour touch screen is a key access point to your device. The extra large customisable 25.9 cm interface gives you the ability to preview thumbnails of documents prior to printing, as well as change print jobs at the device. You can even view, select and print specific pages within a document directly from the touch screen. Its easy-to-use, intuitive navigation provides fast access to the functions and shortcuts.

The following are a few of the Lexmark solutions available through your authorised Lexmark Business Solutions Dealers:



Showroom

Display a customisable, scrolling slideshow on the colour touch screen to promote your business or products, or to communicate important messages to your customers or employees.



Card Copy

Save time and effort in copying identification cards, licenses and insurance cards by automatically scanning, enlarging and copying both sides of a two-sided card onto one side of a sheet of paper.



Background and Idle Screen

Change the touch screen background to your corporate logo, custom images, a unique message or select from preloaded screens.

The following are solutions that come preloaded on the XS950 Family:



Forms and Favorites

Eliminate waste and inefficiencies associated with preprinted forms. Store frequently printed forms, marketing materials or other documents online, then print them on demand.



Scan to Network

Scan a hardcopy document and route the image to one of 100 predefined personal or public shared network folders.



Professional quality output is only part of the story

By leveraging our industry expertise, you can generate efficiency and increase productivity across business processes to gain the power you need to move ahead. Lexmark technology solutions are tailored to your business environment—where business interactions and decisions are happening.

Empower your employees with workflow solutions that refine work processes, capture critical data, and deliver information to the right place, at the right time, and in the right format.

Contact your Lexmark Business Solutions Dealer for specific vertical solutions*. Solutions are customised through your dealer.

Lexmark's standard security features for your network, data and devices

Output security has never been more important to businesses of all sizes. Lexmark's security functions include device management, device hardening and device operation. Strong multilayered security is built-in.

Device management tools include administrative access and passwords, HTTPS, SNMPv3, IP security (IPSec) and 802.1x support to remotely monitor and manage device usage.

Device hardening includes port filtering, TCP connection filtering, hard drive encryption, hard disk wiping, and digitally signed firmware updates which enhances the security of the device's network interface.

Device operation utilises user authentication, address book lookup via LDAP over SSL and device lockout for protection of user information.

Lexmark has shown its strength and leadership with respect to security by:

- ▶ Forming and chairing the group that created the IEEE 2600 standards for security on hardcopy devices.
- ▶ Becoming the first hardcopy device manufacturer to take a holistic approach with the National Information Assurance Partnership (NIAP) Common Criteria evaluation.

* Optional software available. Licensing fees may apply.



Lexmark XS955de colour MFP with optional booklet finisher and 2,000-sheet high capacity feeder.



1. Intuitive colour touch screen

The extra large 25.9 cm colour touch screen allows you to operate your MFP with ease through intuitive navigation and easy access to workflow solutions and shortcuts.

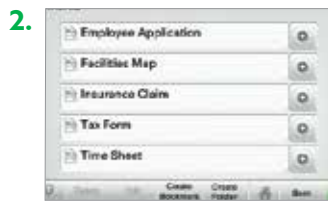

2. Lexmark solutions

Reduce unnecessary printing and simplify work processes through solutions applications preloaded on your device. Choose additional Lexmark solutions to fit your unique workflow needs.



3. Direct USB

The front USB port allows for convenient walk-up preview, printing and scanning, and is compatible with many printable image file formats.



4. Flexible input capacity

Choose the configuration that best fits your needs, up to a maximum of 5,140 sheets.



5. Exceptional media handling

Ultra-reliable paper feeding lets you load up to six different types of media; to support SRA 3 media (320 x 450 mm) and media weight of up to 300 g/m².



6. Advanced finishing options

Easily create professional output inhouse with flexible finishing options, including multi-position stapling, hole punch, expanded output stacking, and booklet capability.

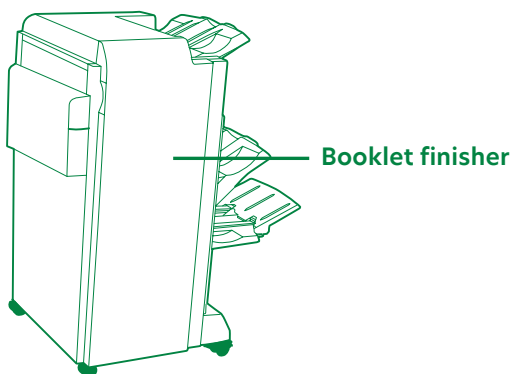
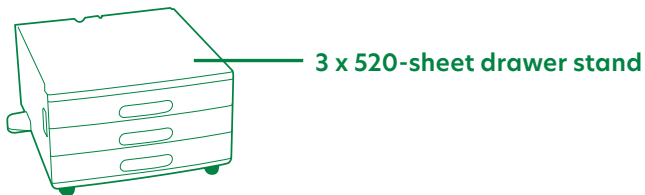
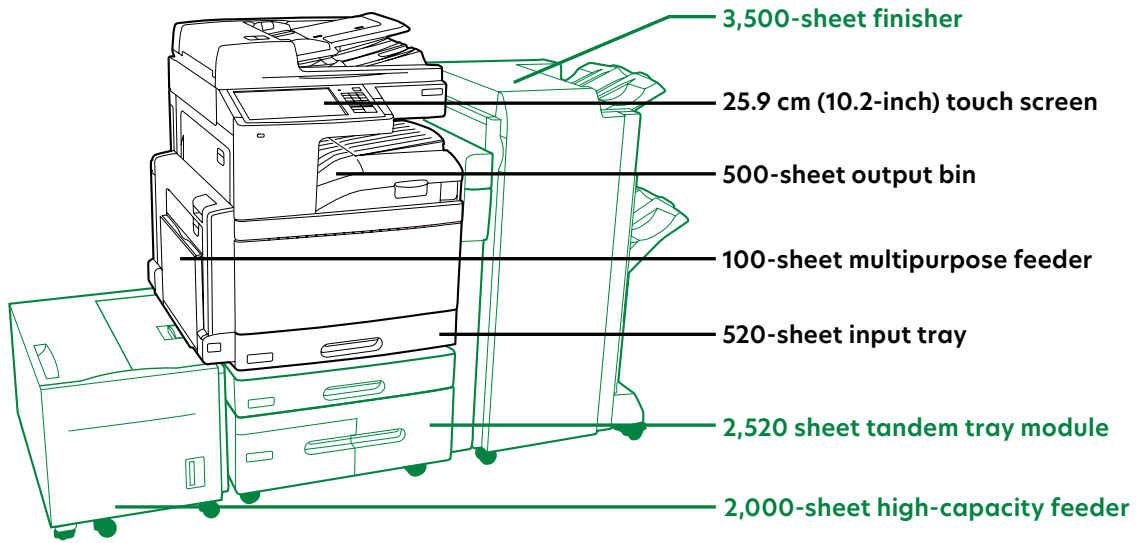

■ Standard
■ Optional

The line art features the standard set-up that can be different per model.



Product specifications	Lexmark XS950de	Lexmark XS955de
Print		
Display	Lexmark e-Task 10-inch (25 cm) class color touch screen	
Print Speed: Up to	Black: 45 ppm / Colour: 40 ppm	Black: 55 ppm / Colour: 50 ppm
Time to First Page: As fast as	Black: 5.5 seconds / Colour: 7.7 seconds	Black: 5.0 seconds / Colour: 7.2 seconds
Print Resolution	Black: 1200 x 1200 dpi, 2400 Image Quality / Colour: 1200 x 1200 dpi, 2400 Image Quality	
Memory	Standard: 1024 MB / Maximum: 2048 MB	Standard: 2048 MB / Maximum: 2048 MB
Hard Disk	Included in configuration	
Recommended Monthly Page Volume ²	5000 - 33000 pages	
Maximum Monthly Duty Cycle: Up to ³	200000 pages per month	250000 pages per month
Copy		
Copy Speed: Up to	Black: 45 cpm / Colour: 40 cpm	Black: 55 cpm / Colour: 50 cpm
Time to First Copy: as fast as	Black: 7.1 seconds / Colour: 10.4 seconds	Black: 6.4 seconds / Colour: 9.9 seconds
Scan		
Scanner Type / ADF Scan	Flatbed scanner with ADF / RADF (reversing Duplex)	
A4/Ltr Duplex Scan Speed: Up to	Black: 38 / 37 sides per minute / Colour: 38 / 37 sides per minute	
A4/Ltr Simplex Scan Speed: Up to	Black: 68 / 70 sides per minute / Colour: 53 / 53 sides per minute	Black: 68 / 70 sides per minute / Colour: 52 / 52 sides per minute
ADF Paper Input Capacity: Up to	110 pages 75 gsm bond	
Fax		
Modem Speed	33.6 Kbps	
Supplies		
Supplies Yield ¹	22,000-page Colour (CMY) Toner Cartridges, 32,000-page Black Toner Cartridge	
Photoconductor Estimated Yield: Up to ⁴	115000 pages, based on 3 average letter/A4-size pages per print job and ~ 5% coverage	
Cartridge(s) Shipping with Product ⁵	11,000-page Colour (CMY) Starter Toner Cartridges, 16,000-page Black Starter Toner Cartridge	
Paper Handling		
Paper Handling Standard	500-Sheet Output Bin, Integrated Duplex, 100-Sheet Multipurpose Feeder, 520-Sheet Input Tray	
Paper Handling Optional	Banner Media Tray, 2,000-Sheet High Capacity Feeder, 3,500-Sheet Finisher, 3 x 520-Sheet Drawer Stand, Booklet Finisher, 2,520-Sheet Tandem Tray Module, 520-Sheet Drawer Stand	
Paper Input Capacity: Up to	Standard: 620 pages 75 gsm bond / Maximum: 5140 pages 75 gsm bond	
Paper Output Capacity: Up to	Standard: 500 pages 75 gsm bond / Maximum: 3750 pages 75 gsm bond	
Media Types Supported	Card Stock, Envelopes, Glossy paper, Labels, Plain Paper, Transparencies, Refer to the Card Stock & Label Guide.	
Media Sizes Supported	10 Envelope, 7 3/4 Envelope, A3, A4, A5, C5 Envelope, DL Envelope, Executive, Folio, JIS-B4, JIS-B5, Ledger, Legal, Letter, Statement, Universal, Super Tabloid (12 x 18"), Oficio, A6	
General Information		
Standard Connectivity	USB 2.0 Specification Hi-Speed Certified (Type B), Front USB 2.0 Specification Hi-Speed Certified port (Type A), Rear USB 2.0 Specification Hi-Speed Certified port (Type A), Ethernet 10/100/1000 BaseTX (RJ-45)	
Optional Network Ports / Optional Local Ports	Internal MarkNet™ N8130 Fiber Fast Ethernet, Internal MarkNet™ N8250 802.11b/g/n Wireless / Internal RS-232C serial, Internal 1284-B Bidirectional Parallel	
Noise Level: Operating	Print: 52 dBA / Copy: 55 dBA / Scan: 55 dBA	Print: 53 dBA / Copy: 55 dBA / Scan: 54 dBA
Specified Operating Environment	Altitude: 0 - 2500 Meters (8,200 Feet), Temperature: 10 to 32°C (50 to 90°F), Humidity: 15 to 85% Relative Humidity	
Size (mm - H x W x D) / Weight	762 x 640 x 685 mm / 116.0 kg	



Vragen? Bel 055-5401004
of e-mail info@nnpartners.nl

¹Yield at approximately 5% coverage per colour ²Recommended Monthly Page Volume" is a range of pages that helps customers evaluate Lexmark's product offerings based on the average number of pages customers plan to print on the device each month. Lexmark recommends that the number of pages per month be within the stated range for optimum device performance, based on factors including: supplies replacement intervals, paper loading intervals, speed, and typical customer usage. ³Maximum Monthly Duty Cycle" is defined as the maximum number of pages a device could deliver in a month using a multishift operation. This metric provides a comparison of robustness in relation to other Lexmark printers and MFPs. ⁴Actual Yield may vary based on other factors such as device speed, paper size and feed orientation, toner coverage, tray source, percentage of black-only printing and average print job complexity. ⁵Average continuous black or continuous composite CMY declared cartridge yield up to this number of standard pages in accordance with ISO/IEC 19798.

This is a Class A device according to the FCC Rules and EN 55022/EN 55032 emissions standards. This device is not intended for use in residential or domestic environments due to potential interference to radio communications.

© 2015 Lexmark and the Lexmark logo are trademarks of Lexmark International, Inc., registered in the United States and/or other countries. All other trademarks are the property of their respective owners. ENERGY STAR® is a U.S. registered mark.

AirPrint and the AirPrint logo are trademarks of Apple Inc.